



JOHN DEERE

24 - 27 METRIC TONS

D

EXCAVATORS

240D LC | 270D LC





Armed forces.

Bigger, stronger, faster, and quieter. The new 240D LC and 270D LC are armed and ready to take on your world. Both deliver the power, smoothness, ease of operation, and comfort you'd expect from John Deere excavators — and then some. Each features a rugged, fuel-efficient Tier 3

PowerTech Plus™ engine; an enhanced cooling system; and extended service intervals for industry-leading uptime and serviceability. And with other refinements such as faster hydraulics, better visibility, and a roomier, more comfortable cab, Deere once again sets the standard.



Specifications	240D LC	270D LC
Net Horsepower	177 hp	188 hp
Operating Weight	54,624 lb.	63,425 lb.
Lift Capacity	16,877 lb.	19,727 lb.
Digging Depth	24 ft. 7 in.	25 ft. 11 in.
Arm Breakout Force	24,020 lb.	25,979 lb.

- 240D LC and 270D LC deliver more digging force, swing torque, and lift capability, with less emissions and noise.
- Extended engine and hydraulic oil service intervals increase uptime and reduce daily operating costs.
- Redesigned cab is more spacious and has 47-percent more glass for best-in-class comfort and visibility.
- Powerwise™ III engine/hydraulic management system maximizes power output, saves fuel, and delivers smooth multifunction hydraulic operation.
- Hydraulically driven, highly efficient fan runs only as needed, reducing noise, fuel consumption, and operating costs.
- Tier 3 emission-certified PowerTech Plus diesels deliver power without compromise in all conditions.

Electronically controlled variable-geometry turbo-charger (VGT) improves torque response, helping match engine speed to load requirements.

Noise levels — and operator fatigue — have been significantly reduced. Variable-speed fan, dual-pass muffler, pilot-injected PowerTech Plus engine, and isochronous high-idle speed help quiet things down.

Cooled exhaust gas recirculation (EGR), four-valve-per-cylinder head, and high-pressure common-rail fuel system enable the 6.8-L diesels to meet Tier 3 emission standards without sacrificing power or fuel efficiency.

Additional hydraulic capability a necessity? Two factory-installed high-pressure, high-flow auxiliary hydraulic packages enable you to meet the need.

Choose from a variety of track widths, arm lengths, buckets, and other options.



1

1. Powerwise III perfectly balances engine performance and hydraulic flow for fast, smooth, and predictable operation. One work mode makes it easy to be productive in any application.



2

2. Significant increases in horsepower, weight, dig force, and drawbar pull make the D-Series highly productive machines for a wide variety of work.

3. Increased flow, arm force, and swing torque help speed cycles, enabling you to load more trucks or open more trench.

4. For work that requires extra finesse, the D-Series' best-in-class metering and smooth multifunction operation give you the precise control you need.



3



4

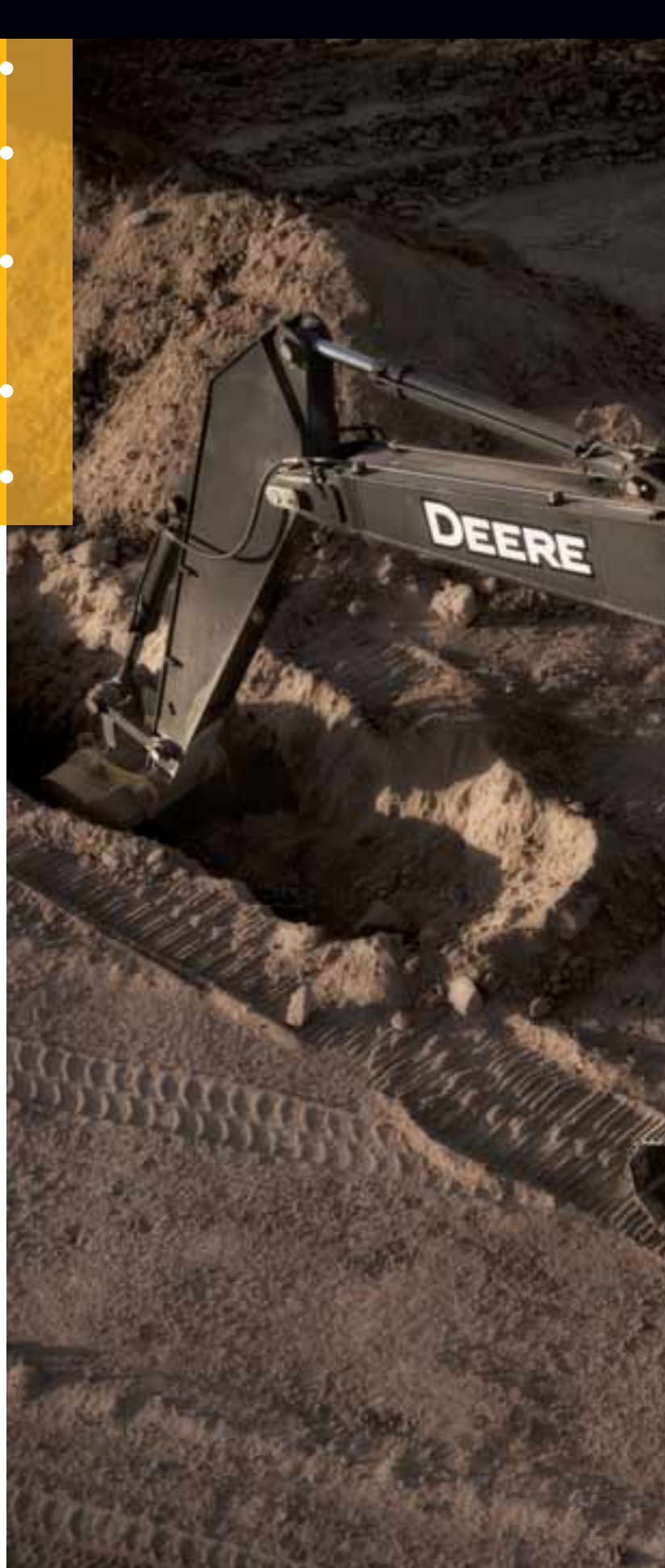

Quietly go about your business of building your bottom line.

D-Series Excavators speak softly and carry a big stick. Combining strong digging forces with outstanding lift capacity and reach, the 240D LC and 270D LC are more than up to any task. Faster hydraulics boost productivity, while increased drawbar pull and arm force provide an additional lift to production.

The Powerwise III engine/hydraulic management system provides pinpoint metering and low-effort control, while numerous noise-reduction enhancements further reduce operator fatigue. Add any of the many available options, and put even more work within reach.





See more, do more.

Yours aren't just any employees. Why equip them with just another excavator? To help make the most of their skills, put your operators behind the controls of a John Deere D-Series. Its spacious, well-appointed interior boasts more of everything. Forty-seven-percent more glass for virtually unrestricted visibility. Substantially more legroom.

And a bevy of creature comforts, including automatic climate control, AM/FM radio, generous storage space, and available air-suspension heated seat. But it's not just the extras that will make your operators more productive. They'll also benefit from the things the D-Series deliver less of — such as noise, fatigue, and emissions.



Deluxe-suspension multi-position seat has 10½ inches of travel, sliding together or independently of the control console. So it won't cramp an operator's style.

Ergonomically correct short-throw pilot levers provide smooth, predictable fingertip control with less movement or effort.

Pushbuttons in the right lever allow fingertip control of auxiliary hydraulic flow for operating attachments.

Convenient 12-volt port powers cell phones and other electronic devices.

Redesigned cab isn't just roomier, it's also noticeably quieter and more comfortable. Silicone-filled mounts effectively isolate operators from noise and vibration.

1. Wide expanse of glass, narrow front cab posts, large overhead tinted hatch, and numerous mirrors provide virtually unobstructed all-around visibility.
2. No shortage of storage in here. There's a place for a cooler, cup holders, and even a hot/cold box that keeps beverages at just the right temperature.
3. Automatic, high-velocity bi-level climate-control system with automotive-style adjustable louvers helps keep the glass clear and the cab comfortable.
4. Intuitive, multi-language monitor provides a wealth of machine info and control. Its LCD four-color screen displays operating, diagnostic, and maintenance data with easy-on-the-eyes clarity.



Graphite-iron wet-sleeve cylinder liners, mono-steel pistons, and large-diameter connecting rods ensure long-term engine durability.

Welded bulkheads within the boom resist torsional stress. Reinforced D-channel side frames provide maximum cab and component protection.

Tungsten-carbide coating creates an extremely wear-resistant surface to protect the all-important bucket-to-arm joint.

An optional reversing fan back-blows cooler cores to reduce debris buildup. It's a welcome addition that will increase uptime.

Oil-impregnated bushings enhance durability and extend grease intervals to 500 hours for the arm-and-boom joint and 100 hours for the bucket joint.

Booms, arms, and mainframes are so tough, they're warranted for three years or 10,000 hours.

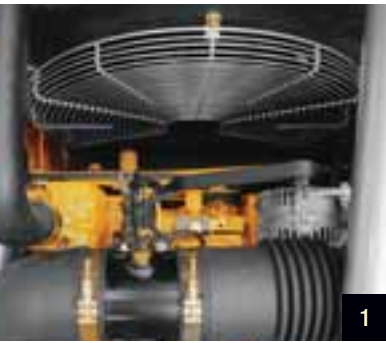

1. Hydraulically driven cool-on-demand fan runs only as needed, reducing fuel consumption and debris flow through the coolers. Highly efficient system keeps things cool, even in tough environments or high altitudes.



2. Perforations in the hood and side shields serve as a "first filter," helping prevent trash entry. Anything that passes through will also clear the eight-fin-per-inch cooler cores.



3. Reinforced resin thrust plates, grooved bushings, and thermal-coated bucket joints increase arm and boom lube intervals to 500 hours.



4. You won't find a more durable swing bearing or mainframe on comparable-size excavators.



Nothing runs like a Deere because nothing is built like one.



From their durable sealed and lubricated undercarriages to their heavy-duty fuel-sipping PowerTech Plus engines, the D-Series are built to the hilt to deliver unsurpassed reliability. These plus numerous other traditional John Deere features such as wet-sleeve engine liners,

tungsten-carbide thermal-coated arm surfaces, oil-impregnated bushings, welded-boom bulkheads, and extended engine and hydraulic oil-change intervals help keep downtime down and profits up. When you know how they're built, you'll run a Deere.

Machine Information Center (MIC) captures and stores vital machine performance and utilization data to help improve uptime, productivity, and profit.

Auto-idle automatically reduces engine speed when hydraulics aren't in use, helping make the most of every precious drop of fuel.

Large easy-to-open doors provide quick access to service items. Lube banks, filters, and checkpoints are grouped for added convenience.

Large fuel tanks and 500- and 5,000-hour engine and hydraulic oil-service intervals increase uptime and help lower daily operating costs.

Fluid-level sight gauges are conveniently located and can be checked at a glance.

Nobody backs you better than the 500-plus John Deere dealers throughout North America.



Minimize maintenance, maximize results.

As with all John Deere machines, D-Series Excavators are loaded with features that make them hassle free to service and low cost to maintain. Large, easy-to-open service doors and easy-to-reach daily service points make quick work of the daily routine. Remote-mounted vertical

oil and fuel filters and extended engine and hydraulic oil-change intervals minimize periodic maintenance, too. Plus, the Machine Information Center (MIC) and remote fluid-sample ports help you make timely decisions about machine upkeep, further minimizing downtime and expense.

1. Vertical spin-on engine oil and fuel/water filters are positioned in the right rear compartment for simplified servicing.

4. Coolers' eight-fin-per-inch spacing lets trash easily pass to resist plugging. Hinged, swing-out coolers provide added core access.

2. Ground-level fresh-air cab filter is quickly serviced from outside the cab. Where it's more likely to get done.

5. Remote diagnostic and fluid-sample ports help speed preventative maintenance and troubleshooting.

3. Centralized lube banks place difficult-to-lube zerks within easy reach. Help make greasing less messy and time consuming, too.

6. Convenient door atop the hood speeds and simplifies daily engine oil and coolant checks.

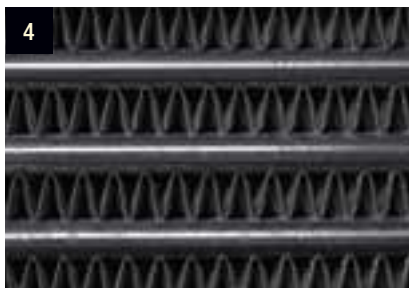

Specifications

Engine

240D LC

Type	John Deere 6068H with altitude-compensating turbocharger and air-to-air charge air cooler; certified to EPA Tier 3 emissions
Net Peak Power (ISO9249)	177 hp (132 kW) @ 2,000 rpm
Net Peak Torque (ISO9249)	576 lb.-ft. (781 Nm) @ 1,400 rpm
Cylinders	6
Displacement	414 cu. in. (6.8 L)
Cooling Fan	suction-type, hydraulic-driven, remote-mounted drive
Electrical System	24 volt with 80-amp alternator
Batteries (two 12 volt)	reserve capacity: 180 min.
Off-level capacity	100% (45 deg.)

Hydraulic System

Main Pumps	two variable-displacement axial-piston
Maximum Flow	2 x 59.2 gpm (2 x 224 L/min.)
Pilot Pump	one gear
Maximum Flow	8.9 gpm (34 L/min.)
Pressure Setting	580 psi (4000 kPa)
System Operating Pressure	
Implement Circuits	4,980 psi (34 300 kPa)
Travel Circuits	4,980 psi (34 300 kPa)
Swing Circuits	4,700 psi (32 400 kPa)
Power Boost	5,260 psi (36 300 kPa)
Oil Filtration	one 10-micron full-flow return filter with by-pass / one pilot oil filter

Cylinders

	Bore	Rod Diameter	Stroke
Boom (2)	4.9 in. (125 mm)	3.5 in. (90 mm)	54.7 in. (1390 mm)
Arm (1)	5.5 in. (140 mm)	3.9 in. (100 mm)	63.4 in. (1610 mm)
Bucket (1)	5.1 in. (130 mm)	3.5 in. (90 mm)	42.3 in. (1075 mm)

Swing Mechanism

Swing Speed	0–13.5 rpm
Swing Torque	54,857 lb.-ft. (74 433 Nm)

Undercarriage

Carrier Rollers (per side)	2
Track Rollers (per side)	9
Shoes, Triple Semi-Grouser (per side)	51
Track Guides	front and center
Track Adjustment	hydraulic
Travel Speed	
Low	0–2.1 mph (0–3.4 km/h)
High	0–3.4 mph (0–5.5 km/h)
Drawbar Pull	49,920 lb. (22 650 kg)

Ground Pressure Data

240D LC

Average Ground Pressure

- 28-in. (700 mm) Triple Semi-Grouser Shoes
(recommended for rocky terrain/stumps) . . . 6.02 psi (41.5 kPa)
- 32-in. (800 mm) Triple Semi-Grouser Shoes
(recommended for general/soft terrain) . . . 5.34 psi (36.8 kPa)

Capacities (U.S.)

- Fuel Tank 132 gal. (500 L)
- Cooling System 31.6 qt. (29.9 L)
- Engine Lubrication, Including Filter 26 qt. (24.6 L)
- Hydraulic Tank 39 gal. (147.6 L)
- Hydraulic System 63.4 gal. (240 L)
- Propel Gearbox (each) 6.5 qt. (6.2 L)
- Swing Drive 7.5 qt. (7 L)

SAE Operating Weights

- With Full Fuel Tank; 175-lb. (79 kg) Operator;
1.38-cu.-yd. (1.06 m³), 42-in. (1065 mm),
2,195-lb. (996 kg) Bucket; 11-ft. 10-in.
(3.61 m) Arm; 11,904-lb. (5400 kg) Counter-
weight; and 32-in. (800 mm) Triple Semi-
Grouser Shoes. 54,654 lb. (24 791 kg)

Component Weights

- Undercarriage
 - 28-in. (700 mm) Triple Semi-Grouser Shoes . . . 18,650 lb. (8460 kg)
 - 32-in. (800 mm) Triple Semi-Grouser Shoes . . . 19,277 lb. (8744 kg)
- One-Piece Boom (with arm cylinder) 4,868 lb. (2208 kg)
- Arm with Bucket Cylinder and Linkage
 - 9 ft. 9 in. (2.96 m) 2,855 lb. (1295 kg)
 - 11 ft. 10 in. (3.61 m) 3,075 lb. (1395 kg)
- Boom Lift Cylinders (2) Total Weight 957 lb. (434 kg)
- 1.38-cu.-yd. (1.06 m³), 42-in. (1065 mm)
Heavy-Duty Plate-Lip Bucket 2,195 lb. (996 kg)
- Counterweight 11,904 lb. (5400 kg)

Operating Information

	Arm Length 9 ft. 9 in. (2.96 m)	Arm Length 11 ft. 10 in. (3.61 m)
Arm Force with 32-in. (800 mm) Triple Semi-Grouser Shoes*	27,640 lb. (122.9 kN)	24,020 lb. (106.8 kN)
Bucket Digging Force with 32-in. (800 mm) Triple Semi-Grouser Shoes*	37,670 lb. (167 kN)	37,670 lb. (167 kN)
Lifting Capacity Over Front @ Ground Level 20-ft. (6.1 m) Reach*	17,721 lb. (8038 kg)	16,877 lb. (7655 kg)
A Maximum Reach	33 ft. 5 in. (10.19 m)	35 ft. 6 in. (10.81 m)
A' Maximum Reach @ Ground Level	32 ft. 9 in. (9.99 m)	34 ft. 11 in. (10.64 m)
B Maximum Digging Depth	22 ft. 5 in. (6.84 m)	24 ft. 7 in. (7.49 m)
B' Maximum Digging Depth @ 8-ft. (2.44 m) Flat Bottom	21 ft. 9 in. (6.63 m)	24 ft. 1 in. (7.33 m)
C Maximum Cutting Height	33 ft. 2 in. (10.12 m)	34 ft. 6 in. (10.52 m)
D Maximum Dumping Height	23 ft. 6 in. (7.16 m)	24 ft. 9 in. (7.54 m)
E Minimum Swing Radius	11 ft. 3 in. (3.44 m)	11 ft. 4 in. (3.46 m)
F Maximum Vertical Wall	19 ft. 5 in. (5.91 m)	21 ft. 9 in. (6.63 m)
G Tail Swing Radius	9 ft. 8 in. (2.94 m)	9 ft. 8 in. (2.94 m)

*Digging forces and lift capacities with power boost.

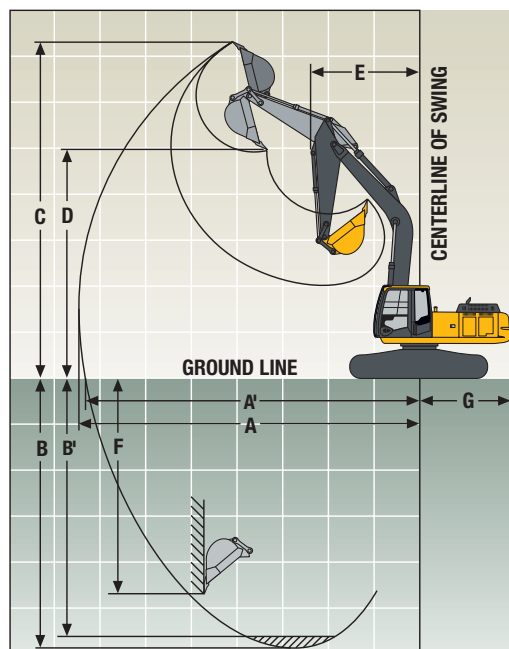

Dimensions

240D LC

- A** 9-ft. 9-in. (2.96 m) arm 10 ft. 1 in. (3.07 m)
 11-ft. 10-in. (3.61 m) arm 10 ft. 4 in. (3.14 m)
- B** 9-ft. 9-in. (2.96 m) arm 33 ft. 4 in. (10.15 m)
 11-ft. 10-in. (3.61 m) arm 33 ft. 6 in. (10.21 m)

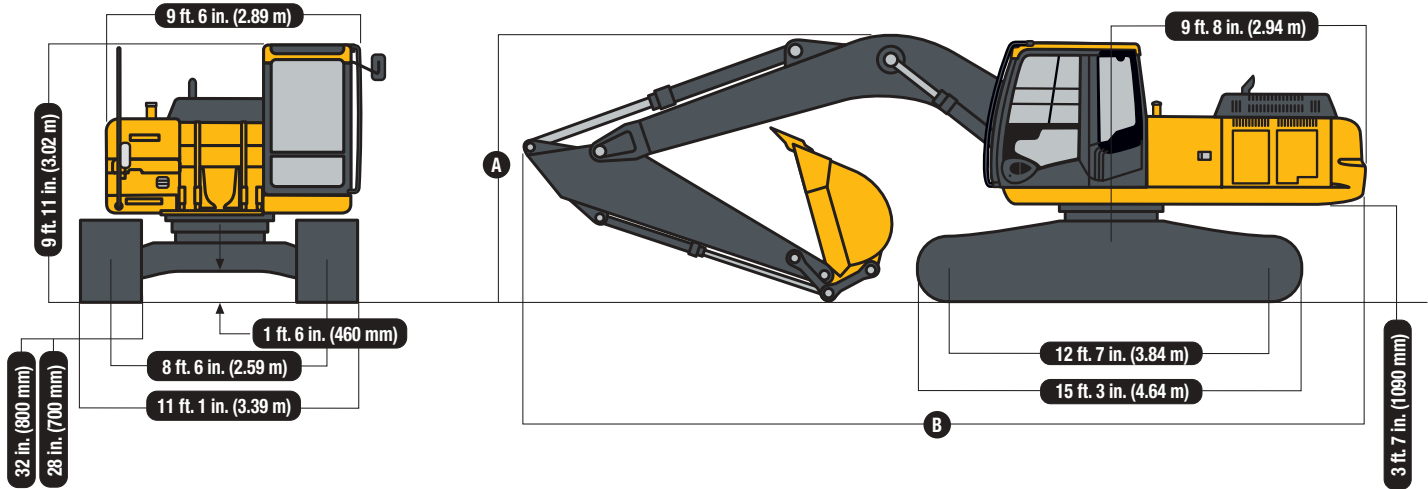

Lift Capacities

Boldface italic type indicates hydraulic-limited capacities; lightface type indicates stability-limited capacities, in lb. (kg). Ratings at bucket lift hook; machine equipped with 1.38-cu.-yd. (1.06 m³), 42-in. (1065 mm), 2,195-lb. (996 kg) bucket; 11,904-lb. (5400 kg) counterweight; standard gauge; and situated on firm, uniform supporting surface. Total load includes weight of cables, hook, etc. Figures do not exceed 87 percent of hydraulic capacities or 75 percent of weight needed to tip machine. All lift capacities are based on SAE J1097.

Load Point Height	10 ft. (3.05 m)		15 ft. (4.57 m)		20 ft. (6.10 m)		25 ft. (7.62 m)		30 ft. (9.15 m)	
	Over Front	Over Side	Over Front	Over Side	Over Front	Over Side	Over Front	Over Side	Over Front	Over Side
<i>With 11-ft. 10-in. (3.61 m) arm and 32-in. (800 mm) triple semi-grouser shoes</i>										
20 ft. (6.10 m)							7,549 (3424)	7,549 (3424)		
15 ft. (4.57 m)					8,518 (3864)	8,518 (3864)	8,607 (3904)	8,607 (3904)	6,261 (2840)	6,261 (2840)
10 ft. (3.05 m)			14,688 (6662)	14,688 (6662)	11,557 (5242)	11,557 (5242)	10,049 (4558)	8,879 (4027)	8,091 (3670)	6,289 (2853)
5 ft. (1.52 m)			20,756 (9415)	18,889 (8568)	14,486 (6571)	12,098 (5488)	11,624 (5273)	8,385 (3803)	9,678 (4390)	6,038 (2739)
Ground Line			24,563 (11 142)	17,619 (7992)	16,877 (7655)	11,347 (5147)	12,785 (5799)	7,956 (3609)	9,457 (4290)	5,809 (2635)
-5 ft. (-1.52 m)	13,061 (5924)	13,061 (5924)	25,705 (11 660)	17,163 (7785)	17,903 (8121)	10,923 (4955)	12,480 (5661)	7,678 (3483)	9,308 (4222)	5,670 (2572)
-10 ft. (-3.05 m)	22,506 (10 209)	22,506 (10 209)	25,004 (11 342)	17,154 (7781)	17,768 (8060)	10,804 (4901)	12,387 (5619)	7,593 (3444)		
-15 ft. (-4.57 m)	29,633 (13 441)	29,633 (13 441)	22,540 (10 224)	17,460 (7920)	16,709 (7579)	10,961 (4972)	12,307 (5582)	7,768 (3524)		
-20 ft. (-6.10 m)			17,275 (7836)	17,275 (7836)	12,097 (5487)	11,532 (5231)				
<i>With 11-ft. 10-in. (3.61 m) arm and 28-in. (700 mm) triple semi-grouser shoes</i>										
20 ft. (6.10 m)							7,549 (3424)	7,549 (3424)		
15 ft. (4.57 m)					8,518 (3864)	8,518 (3864)	8,607 (3904)	8,607 (3904)	6,261 (2840)	6,261 (2840)
10 ft. (3.05 m)			14,688 (6662)	14,688 (6662)	11,557 (5242)	11,557 (5242)	10,049 (4558)	8,775 (3980)	8,091 (3670)	6,206 (2815)
5 ft. (1.52 m)			20,756 (9415)	18,696 (8480)	14,486 (6571)	11,961 (5425)	11,624 (5273)	8,282 (3757)	9,578 (4345)	5,955 (2701)
Ground Line			24,563 (11 142)	17,417 (7900)	16,877 (7655)	11,210 (5085)	12,627 (5728)	7,853 (3562)	9,332 (4233)	5,726 (2597)
-5 ft. (-1.52 m)	13,061 (5924)	13,061 (5924)	25,705 (11 660)	16,960 (7693)	17,687 (8023)	10,786 (4892)	12,322 (5589)	7,574 (3436)	9,183 (4165)	5,587 (2534)
-10 ft. (-3.05 m)	22,506 (10 209)	22,506 (10 209)	25,004 (11 342)	16,952 (7689)	17,551 (7961)	10,666 (4838)	12,229 (5547)	7,489 (3397)		
-15 ft. (-4.57 m)	29,633 (13 441)	29,633 (13 441)	22,540 (10 224)	17,257 (7828)	16,709 (7579)	10,824 (4910)	12,307 (5582)	7,664 (3476)		
-20 ft. (-6.10 m)			17,275 (7836)	17,275 (7836)	12,097 (5487)	11,395 (5169)				
<i>With 9-ft. 9-in. (2.96 m) arm and 32-in. (800 mm) triple semi-grouser shoes</i>										
20 ft. (6.10 m)							8,237 (3736)	8,237 (3736)		
15 ft. (4.57 m)					10,540 (4781)	10,540 (4781)	9,885 (4484)	9,122 (4138)		
10 ft. (3.05 m)			17,515 (7945)	17,515 (7945)	13,047 (5918)	12,726 (5772)	11,074 (5023)	8,728 (3959)	7,205 (3268)	6,196 (2810)
5 ft. (1.52 m)			23,155 (10 503)	18,262 (8284)	15,755 (7146)	11,858 (5379)	12,482 (5662)	8,288 (3759)	9,206 (4176)	6,004 (2723)
Ground Line			25,634 (11 628)	17,416 (7900)	17,721 (8038)	11,241 (5099)	12,744 (5781)	7,930 (3597)	9,235 (4189)	5,837 (2648)
-5 ft. (-1.52 m)	12,761 (5788)	12,761 (5788)	25,654 (11 637)	17,248 (7824)	17,922 (8129)	10,954 (4969)	12,530 (5684)	7,734 (3508)		
-10 ft. (-3.05 m)	19,352 (8778)	19,352 (8778)	24,124 (10 943)	17,398 (7892)	17,921 (8129)	10,953 (4968)	12,548 (5692)	7,750 (3515)		
-15 ft. (-4.57 m)	27,603 (12 521)	27,603 (12 521)	20,730 (9403)	17,836 (8090)	15,487 (7025)	11,247 (5102)				

Lift Capacities (continued)

240D LC

Boldface italic type indicates hydraulic-limited capacities; lightface type indicates stability-limited capacities, in lb. (kg). Ratings at bucket lift hook; machine equipped with 1.38-cu.-yd. (1.06 m³), 42-in. (1065 mm), 2,195-lb. (996 kg) bucket; 11,904-lb. (5400 kg) counterweight; standard gauge; and situated on firm, uniform supporting surface. Total load includes weight of cables, hook, etc. Figures do not exceed 87 percent of hydraulic capacities or 75 percent of weight needed to tip machine. All lift capacities are based on SAE J1097.

Load Point Height	10 ft. (3.05 m)		15 ft. (4.57 m)		20 ft. (6.10 m)		25 ft. (7.62 m)		30 ft. (9.15 m)	
	Over Front	Over Side	Over Front	Over Side	Over Front	Over Side	Over Front	Over Side	Over Front	Over Side
<i>With 9-ft. 9-in. (2.96 m) arm and 28-in. (700 mm) triple semi-grouser shoes</i>										
20 ft. (6.10 m)							8,237 (3736)	8,237 (3736)		
15 ft. (4.57 m)					10,540 (4781)	10,540 (4781)	9,885 (4484)	9,018 (4091)		
10 ft. (3.05 m)			17,515 (7945)	17,515 (7945)	13,047 (5918)	12,589 (5710)	11,074 (5023)	8,625 (3912)	7,205 (3268)	6,113 (2773)
5 ft. (1.52 m)			23,155 (10 503)	18,059 (8192)	15,755 (7146)	11,721 (5317)	12,482 (5662)	8,184 (3712)	9,206 (4176)	5,921 (2686)
Ground Line			25,634 (11 628)	17,213 (7808)	17,721 (8038)	11,104 (5037)	12,586 (5709)	7,826 (3550)	9,235 (4189)	5,753 (2610)
-5 ft. (-1.52 m)	12,761 (5788)	12,761 (5788)	25,654 (11 637)	17,045 (7732)	17,706 (8031)	10,817 (4907)	12,372 (5612)	7,630 (3461)		
-10 ft. (-3.05 m)	19,352 (8778)	19,352 (8778)	24,124 (10 943)	17,196 (7800)	17,705 (8031)	10,816 (4906)	12,389 (5620)	7,646 (3468)		
-15 ft. (-4.57 m)	27,603 (12 521)	27,603 (12 521)	20,730 (9403)	17,634 (7999)	15,487 (7025)	11,110 (5039)				

Buckets

A full line of buckets is offered to meet a wide variety of applications. Digging forces are with power boost. Tooth selection includes either the John Deere Fanggs®, Standard, Tiger, Twin Tiger, Abrasion panel, or Flare tooth, or the ESCO (Vertalok) Standard, Tiger, Twin Tiger, or Flare tooth. Replaceable cutting edges are available through John Deere parts. Optional side cutters add 6 inches (150 mm) to bucket widths.

Type Bucket	Bucket Width		Bucket Capacity*		Weight		Bucket Dig Force		Arm Dig Force 9 ft. 9 in. (2.96 m)		Arm Dig Force 11 ft. 10 in. (3.61 m)		Bucket Tip Radius		No. Teeth
	in.	mm	cu. yd.	m ³	lb.	kg	lb.	kN	lb.	kN	lb.	kN	in.	mm	
Heavy-Duty Plate Lip	42	1065	1.38	1.06	2,195	996	37,676	167.0	27,640	122.9	24,020	106.8	56.5	1435	5
	48	1220	1.60	1.22	2,359	1070	37,676	167.0	27,640	122.9	24,020	106.8	56.5	1435	6
	54	1370	1.82	1.39	2,507	1137	37,676	167.0	27,640	122.9	24,020	106.8	56.5	1435	6
Heavy-Duty High Capacity	24	610	0.92	0.70	1,765	801	35,846	159.4	26,710	118.8	23,313	103.7	62.5	1588	3
	30	760	1.20	0.92	2,010	912	35,846	159.4	26,710	118.8	23,313	103.7	62.5	1588	4
	36	915	1.48	1.13	2,133	968	35,846	159.4	26,710	118.8	23,313	103.7	62.5	1588	4
	42	1065	1.75	1.34	2,279	1034	35,846	159.4	26,710	118.8	23,313	103.7	62.5	1588	5
	48	1200	2.03	1.55	2,505	1136	35,846	159.4	26,710	118.8	23,313	103.7	62.5	1588	6
Severe-Duty Plate Lip	30	760	0.95	0.73	2,080	943	37,676	167.0	27,640	122.9	24,020	106.8	56.5	1435	4
	36	915	1.16	0.89	2,179	988	37,676	167.0	27,640	122.9	24,020	106.8	56.5	1435	4
	42	1065	1.38	1.06	2,345	1064	37,676	167.0	27,640	122.9	24,020	106.8	56.5	1435	5
Ditching	60	1525	1.34	1.02	1,562	709	45,273	201.4	29,244	130.1	25,225	112.2	47.0	1194	0

*All capacities are SAE heaped ratings and with side cutters.

Bucket Selection Guide*

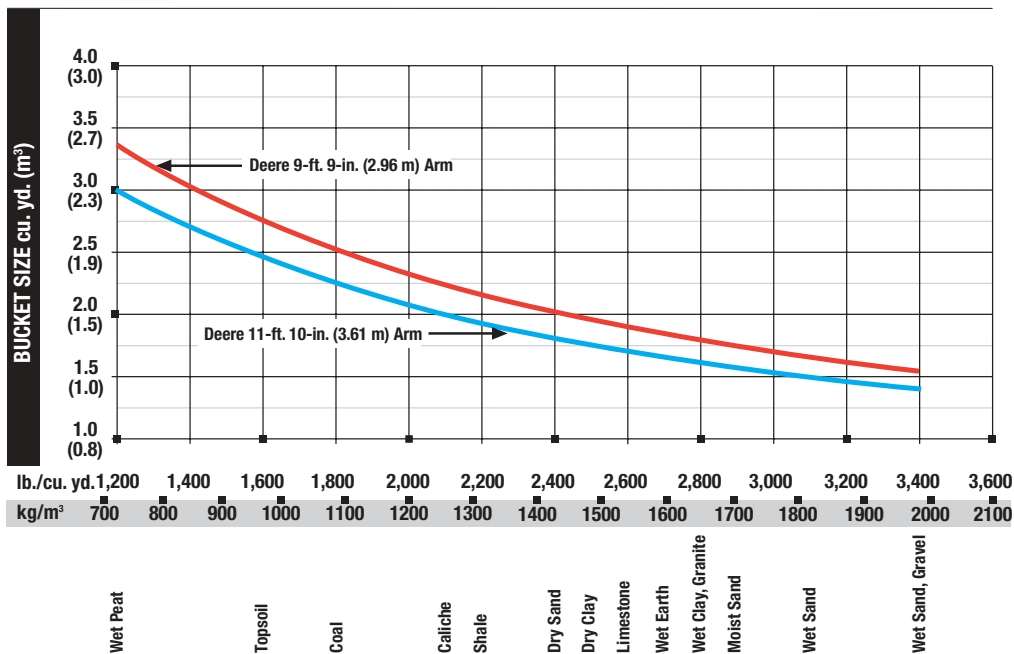

*Contact your John Deere dealer for optimum bucket and attachment selections. These recommendations are for general conditions and average use. Does not include optional equipment such as thumbs or couplers. Larger buckets may be possible when using light materials, for flat and level operations, less compacted materials, and volume loading applications such as mass excavation applications in ideal conditions. Smaller buckets are recommended for adverse conditions such as off-level applications, rocks, and uneven surfaces. Bucket capacity indicated is SAE heaped.

Specifications

Engine

270D LC

Type	John Deere 6068H with altitude-compensating turbocharger and air-to-air charge air cooler; certified to EPA Tier 3 emissions
Net Peak Power (ISO9249)	188 hp (140 kW) @ 2,100 rpm
Net Peak Torque (ISO9249)	599 lb.-ft. (813 Nm) @ 1,400 rpm
Cylinders	6
Displacement	414 cu. in. (6.8 L)
Cooling Fan	suction-type, hydraulic-driven, remote-mounted drive
Electrical System	24 volt with 80-amp alternator
Batteries (two 12 volt)	reserve capacity: 180 min.
Off-level capacity	100% (45 deg.)

Hydraulic System

Main Pumps	two variable-displacement axial-piston
Maximum Flow	2 x 62.3 gpm (2 x 236 L/min.)
Pilot Pump	one gear
Maximum Flow	8.9 gpm (34 L/min.)
Pressure Setting	580 psi (4000 kPa)
System Operating Pressure	
Implement Circuits	4,980 psi (34 300 kPa)
Travel Circuits	4,980 psi (34 300 kPa)
Swing Circuits	4,700 psi (32 400 kPa)
Power Boost	5,260 psi (36 300 kPa)
Oil Filtration	one 10-micron full-flow return filter with by-pass / one pilot oil filter

Cylinders

	Bore	Rod Diameter	Stroke
Boom (2)	5.3 in. (135 mm)	3.7 in. (95 mm)	53.5 in. (1360 mm)
Arm (1)	5.9 in. (150 mm)	4.1 in. (105 mm)	65.3 in. (1659 mm)
Bucket (1)	5.3 in. (135 mm)	3.5 in. (90 mm)	42.1 in. (1070 mm)

Swing Mechanism

Swing Speed	0–12.6 rpm
Swing Torque	56,852 lb.-ft. (77 140 Nm)

Undercarriage

Carrier Rollers (per side)	2
Track Rollers (per side)	8
Shoes, Triple Semi-Grouser (per side)	48
Track Guides	front and center
Track Adjustment	hydraulic
Travel Speed	
Low	0–2.1 mph (0–3.3 km/h)
High	0–3.4 mph (0–5.5 km/h)
Drawbar Pull	56,074 lb. (25 435 kg)

Ground Pressure Data

270D LC

Average Ground Pressure
 32-in. (800 mm) Triple Semi-Grouser Shoes
 (recommended for general/soft terrain) . . . 5.84 psi (40.3 kPa)

Capacities (U.S.)

Fuel Tank 132 gal. (500 L)
 Cooling System 31.6 qt. (29.9 L)
 Engine Lubrication, Including Filter 26 qt. (24.6 L)
 Hydraulic Tank 39 gal. (148 L)
 Hydraulic System 63.4 gal. (240 L)
 Propel Gearbox (each) 9 qt. (8.5 L)
 Swing Drive 8 qt. (7.6 L)

SAE Operating Weights

With Full Fuel Tank; 175-lb. (79 kg) Operator;
 1.75-cu.-yd. (1.34 m³), 42-in. (1065 mm),
 2,279-lb. (1034 kg) Bucket; 12-ft. 4-in.
 (3.75 m) Arm; 13,447-lb. (6100 kg) Counter-
 weight; and 32-in. (800 mm) Triple Semi-
 Grouser Shoes 63,425 lb. (28 770 kg)

Component Weights

Undercarriage
 32-in. (800 mm) Triple Semi-Grouser Shoes . . . 25,937 lb. (11 765 kg)
 One-Piece Boom (with arm cylinder) 5,086 lb. (2307 kg)
 Arm with Bucket Cylinder and Linkage
 10 ft. 2 in. (3.11 m) 3,102 lb. (1407 kg)
 12 ft. 4 in. (3.75 m) 3,298 lb. (1496 kg)
 Boom Lift Cylinders (2) Total Weight 1,098 lb. (494 kg)
 1.75-cu.-yd. (1.34 m³), 42-in. (1065 mm)
 Heavy-Duty High-Capacity Bucket 2,279 lb. (1034 kg)
 Counterweight 13,447 lb. (6100 kg)

Operating Information

	<i>Arm Length</i> 10 ft. 2 in. (3.11 m)	<i>Arm Length</i> 12 ft. 4 in. (3.75 m)
Arm Force with 32-in. (800 mm) Triple Semi-Grouser Shoes*	29,518 lb. (131.3 kN)	25,979 lb. (115.55 kN)
Bucket Digging Force with 32-in. (800 mm) Triple Semi-Grouser Shoes*	37,480 lb. (166.7 kN)	37,480 lb. (166.7 kN)
Lifting Capacity Over Front @ Ground Level		
20-ft. (6.1 m) Reach*	20,773 lb. (9423 kg)	19,727 lb. (8948 kg)
A Maximum Reach	35 ft. 3 in. (10.74 m)	37 ft. 1 in. (11.30 m)
A' Maximum Reach @ Ground Level	34 ft. 7 in. (10.55 m)	36 ft. 6 in. (11.12 m)
B Maximum Digging Depth	23 ft. 10 in. (7.26 m)	25 ft. 11 in. (7.91 m)
B' Maximum Digging Depth @ 8-ft. (2.44 m) Flat Bottom	23 ft. 2 in. (7.05 m)	25 ft. 8 in. (7.72 m)
C Maximum Cutting Height	32 ft. 10 in. (10.01 m)	34 ft. 4 in. (10.46 m)
D Maximum Dumping Height	23 ft. 2 in. (7.07 m)	24 ft. 7 in. (7.49 m)
E Minimum Swing Radius	13 ft. 7 in. (4.41 m)	12 ft. 9 in. (3.89 m)
F Maximum Vertical Wall	20 ft. 1 in. (6.11 m)	23 ft. 1 in. (7.03 m)
G Tail Swing Radius	9 ft. 8 in. (2.94 m)	9 ft. 8 in. (2.94 m)

*Digging forces and lift capacities with power boost.

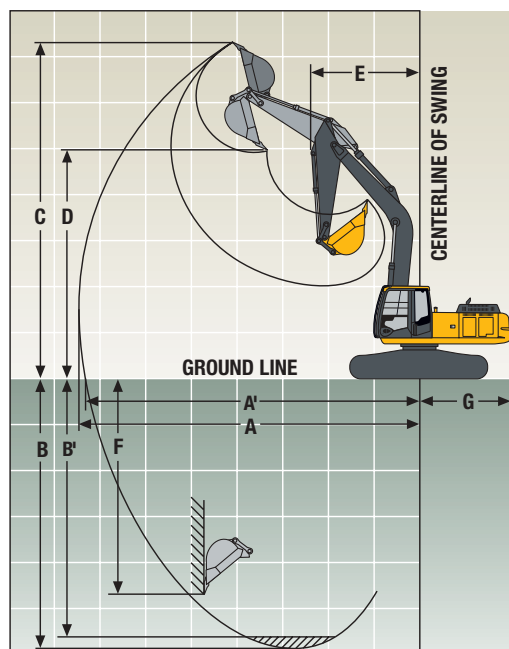

Dimensions

270D LC

- A** 10-ft. 2-in. (3.11 m) arm..... 10 ft. 5 in. (3.17 m)
 12-ft. 4-in. (3.75 m) arm..... 11 ft. 0 in. (3.35 m)
- B** 10-ft. 2-in. (3.11 m) arm..... 33 ft. 11 in. (10.34 m)
 12-ft. 4-in. (3.75 m) arm..... 35 ft. 3 in. (10.74 m)

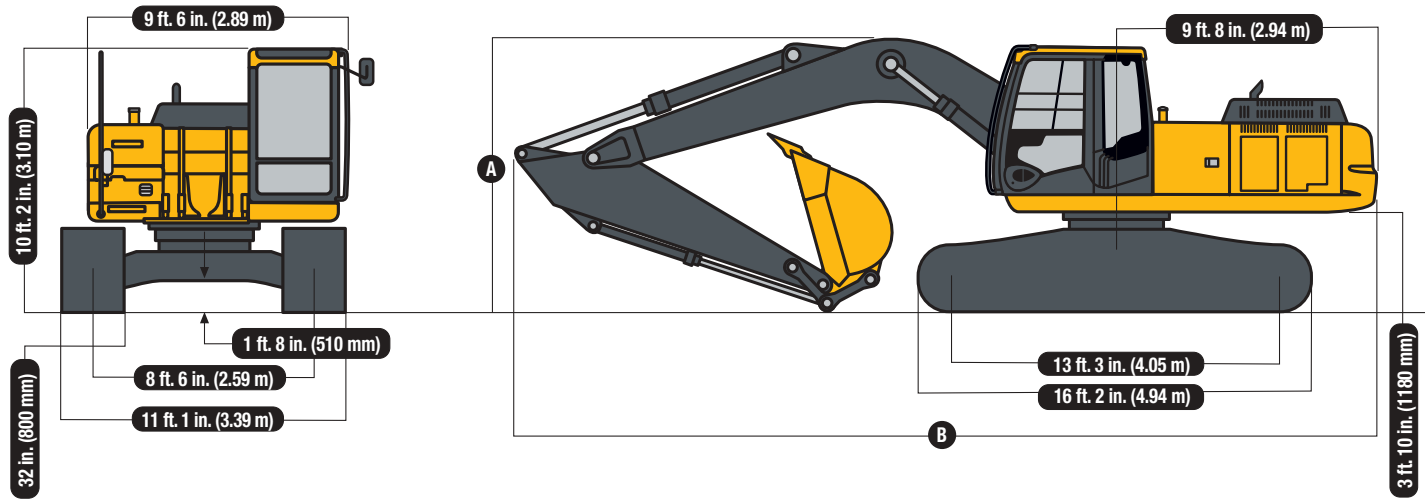

Lift Capacities

Boldface italic type indicates hydraulic-limited capacities; lightface type indicates stability-limited capacities, in lb. (kg). Ratings at bucket lift hook; machine equipped with 1.75-cu.-yd. (1.34 m³), 42-in. (1065 mm), 2,279-lb. (1034 kg) bucket; 13,447-lb. (6100 kg) counterweight; standard gauge; and situated on firm, uniform supporting surface. Total load includes weight of cables, hook, etc. Figures do not exceed 87 percent of hydraulic capacities or 75 percent of weight needed to tip machine. All lift capacities are based on SAE J1097.

Load Point Height	10 ft. (3.05 m)		15 ft. (4.57 m)		20 ft. (6.10 m)		25 ft. (7.62 m)		30 ft. (9.15 m)	
	Over Front	Over Side	Over Front	Over Side	Over Front	Over Side	Over Front	Over Side	Over Front	Over Side
<i>With 12-ft. 4-in. (3.75 m) arm and 32-in. (800 mm) triple semi-grouser shoes</i>										
25 ft. (7.62 m)							8,490 (3851)	8,490 (3851)		
20 ft. (6.10 m)							8,629 (3914)	8,629 (3914)	5,984 (2714)	5,984 (2714)
15 ft. (4.57 m)							9,676 (4389)	9,676 (4389)	9,609 (4359)	7,937 (3600)
10 ft. (3.05 m)			17,039 (7729)	17,039 (7729)	13,189 (5982)	13,189 (5982)	11,405 (5173)	10,668 (4839)	10,524 (4774)	7,680 (3484)
5 ft. (1.52 m)			24,377 (11 057)	22,290 (10 111)	16,795 (7618)	14,398 (6531)	13,401 (6079)	10,091 (4577)	11,626 (5274)	7,371 (3343)
Ground Line			28,866 (13 094)	20,936 (9497)	19,727 (8948)	13,562 (6152)	15,195 (6892)	9,601 (4355)	12,245 (5554)	7,096 (3219)
-5 ft. (-1.52 m)	15,885 (7205)	15,885 (7205)	30,355 (13 769)	20,481 (9290)	21,412 (9712)	13,102 (5943)	16,083 (7295)	9,284 (4211)	12,055 (5468)	6,922 (3140)
-10 ft. (-3.05 m)	22,504 (10 208)	22,504 (10 208)	29,877 (13 552)	20,489 (9294)	21,738 (9860)	12,972 (5884)	15,965 (7242)	9,178 (4163)	10,392 (4714)	6,920 (3139)
-15 ft. (-4.57 m)	30,876 (14 005)	30,876 (14 005)	27,577 (12 509)	20,821 (9444)	20,489 (9294)	13,131 (5956)	15,518 (7039)	9,328 (4231)		
-20 ft. (-6.10 m)	30,941 (14 035)	30,941 (14 035)	22,517 (10 214)	21,537 (9769)	16,452 (7463)	13,673 (6202)				
<i>With 10-ft. 2-in. (3.11 m) arm and 32-in. (800 mm) triple semi-grouser shoes</i>										
20 ft. (6.10 m)							10,107 (4585)	10,107 (4585)		
15 ft. (4.57 m)							10,993 (4986)	10,981 (4981)	8,349 (3787)	7,778 (3528)
10 ft. (3.05 m)			20,484 (9291)	20,484 (9291)	14,959 (6785)	14,959 (6785)	12,603 (5717)	10,494 (4760)	11,531 (5230)	7,587 (3441)
5 ft. (1.52 m)			27,306 (12 386)	21,575 (9786)	18,319 (8309)	14,121 (6405)	14,426 (6544)	9,976 (4525)	12,445 (5645)	7,332 (3326)
Ground Line			28,596 (12 971)	20,733 (9404)	20,773 (9423)	13,441 (6097)	15,959 (7239)	9,564 (4338)	12,256 (5559)	7,117 (3228)
-5 ft. (-1.52 m)	14,458 (6558)	14,458 (6558)	30,272 (13 731)	20,588 (9339)	21,875 (9922)	13,133 (5957)	16,127 (7315)	9,337 (4235)	12,156 (5514)	7,026 (3187)
-10 ft. (-3.05 m)	23,292 (10 565)	23,292 (10 565)	29,066 (13 184)	20,762 (9418)	21,566 (9782)	13,130 (5956)	16,121 (7312)	9,332 (4233)		
-15 ft. (-4.57 m)	29,503 (13 382)	29,503 (13 382)	25,803 (11 704)	21,225 (9628)	19,419 (8808)	13,422 (6088)				

Buckets

270D LC

A full line of buckets is offered to meet a wide variety of applications. Digging forces are with power boost. Tooth selection includes either the John Deere Fanggs®, Standard, Tiger, Twin Tiger, Abrasion panel, or Flare tooth, or the ESCO (Vertalok) Standard, Tiger, Twin Tiger, or Flare tooth. Replaceable cutting edges are available through John Deere parts. Optional side cutters add 6 inches (150 mm) to bucket widths.

Type Bucket	Bucket Width		Bucket Capacity*		Weight		Bucket Dig Force		Arm Dig Force 10 ft. 2 in. (3.11 m)		Arm Dig Force 12 ft. 4 in. (3.75 m)		Bucket Tip Radius		No. Teeth
	in.	mm	cu. yd.	m³	lb.	kg	lb.	kN	lb.	kN	lb.	kN	in.	mm	
Heavy-Duty Plate Lip	42	1065	1.38	1.06	2,195	996	41,476	184.5	30,510	135.7	26,741	118.9	56.5	1435	5
	48	1220	1.60	1.22	2,359	1070	41,476	184.5	30,510	135.7	26,741	118.9	56.5	1435	6
	54	1370	1.82	1.39	2,507	1137	41,476	184.5	30,510	135.7	26,741	118.9	56.5	1435	6
Heavy-Duty High Capacity	24	610	0.92	0.70	1,765	801	37,480	166.7	29,518	131.3	25,979	115.6	62.5	1588	3
	30	760	1.20	0.92	2,010	912	37,480	166.7	29,518	131.3	25,979	115.6	62.5	1588	4
	36	915	1.48	1.13	2,133	968	37,480	166.7	29,518	131.3	25,979	115.6	62.5	1588	4
	42	1065	1.75	1.34	2,279	1034	37,480	166.7	29,518	131.3	25,979	115.6	62.5	1588	5
	48	1200	2.03	1.55	2,505	1136	37,480	166.7	29,518	131.3	25,979	115.6	62.5	1588	6
Severe-Duty Plate Lip	30	760	0.95	0.73	2,080	943	41,476	184.5	30,510	135.7	26,741	118.9	56.5	1435	4
	36	915	1.16	0.89	2,179	988	41,476	184.5	30,510	135.7	26,741	118.9	56.5	1435	4
	42	1065	1.38	1.06	2,345	1064	41,476	184.5	30,510	135.7	26,741	118.9	56.5	1435	5
Ditching	60	1525	1.34	1.02	1,562	709	49,848	221.7	32,225	143.3	28,044	124.7	47.0	1194	0

*All capacities are SAE heaped ratings and with side cutters.

Bucket Selection Guide*

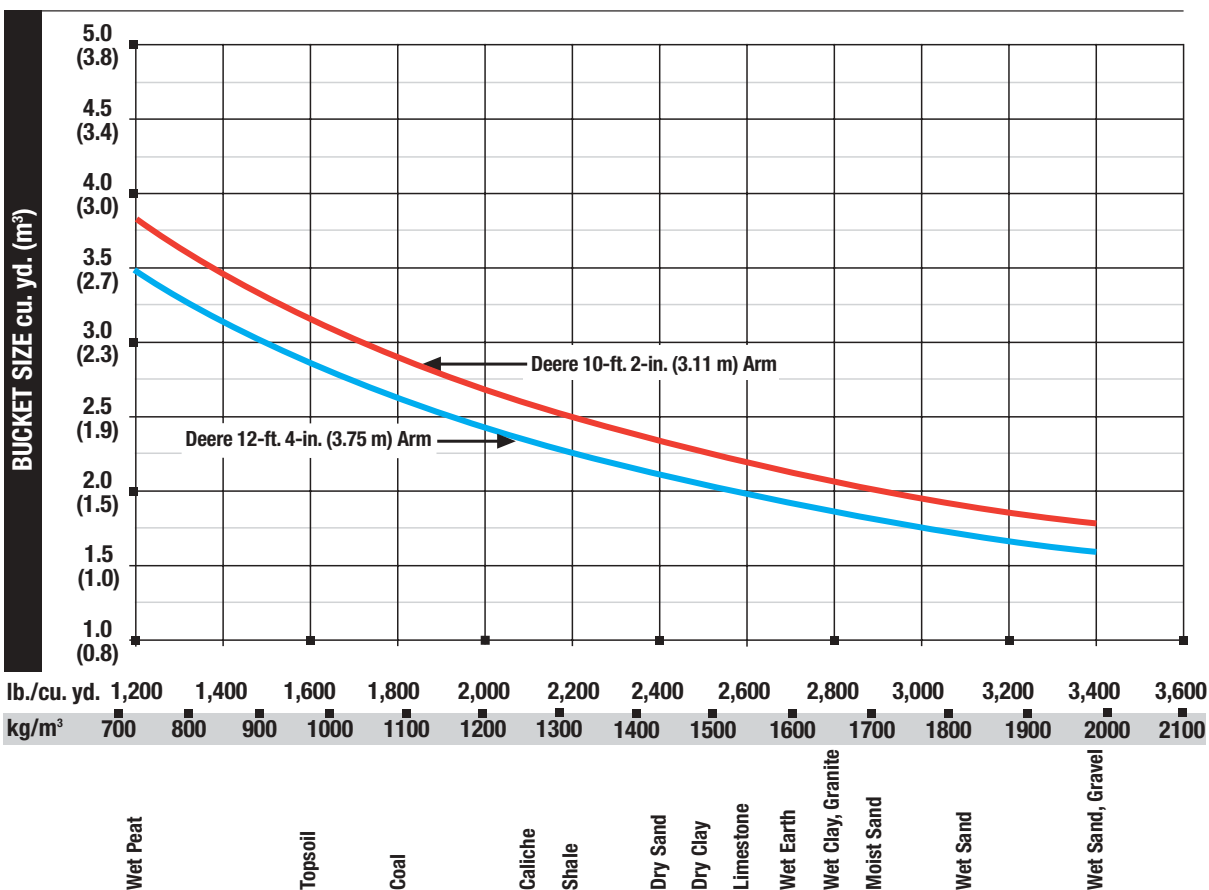

*Contact your John Deere dealer for optimum bucket and attachment selections. These recommendations are for general conditions and average use. Does not include optional equipment such as thumbs or couplers. Larger buckets may be possible when using light materials, for flat and level operations, less compacted materials, and volume loading applications such as mass excavation applications in ideal conditions. Smaller buckets are recommended for adverse conditions such as off-level applications, rocks, and uneven surfaces. Bucket capacity indicated is SAE heaped.

240D LC / 270D LC EXCAVATORS

Key: ● Standard equipment ▲ Optional or special equipment

240D 270D Engine

- ● Certified to EPA Tier 3 emissions
- ● Auto-idle system
- ● Automatic belt tension device
- ● Batteries (two 12 volt), 180-min. reserve capacity
- ● Coolant recovery tank
- ● Dual-element dry-type air filter
- ● Electronic engine control
- ● Enclosed fan guard (conforms to SAE J1308)
- ● Engine coolant to -34°F (-37°C)
- ● Fuel filter with water separator
- ● Full-flow oil filter
- ● Turbocharger with charge air cooler
- ● Muffler, under hood, with vertical curved end exhaust stack
- ● Cool-on-demand hydraulic-driven fan
- ● Glow-plug start aid
- ● 500-hour engine-oil-change interval
- ● 100% (45 deg.) off-level capability
- ● Engine-oil-sampling valve
- ▲ ▲ Hydraulic fan reverser
- ▲ ▲ Engine coolant heater

Hydraulic System

- ● Reduced-drift valve for boom down, arm in
- ● Auxiliary hydraulic valve section
- ● Spring-applied, hydraulically released automatic swing brake
- ● Auxiliary hydraulic-flow adjustments through monitor
- ● Auto power lift
- ● 5,000-hour hydraulic-oil-change interval
- ● Hydraulic-oil-sampling valve
- ▲ ▲ Auxiliary hydraulic lines
- ▲ ▲ Auxiliary pilot and electric controls
- ▲ ▲ Hydraulic filter restriction indicator kit
- ▲ ▲ Load-lowering control device
- ▲ ▲ Single-pedal propel control
- ▲ ▲ Control pattern change valve

Undercarriage

- ● Planetary drive with axial piston motors
- ● Propel motor shields
- ● Spring-applied, hydraulically released automatic propel brake
- ● Track guides, front idler and center
- ● Two-speed propel with automatic shift
- ● Upper carrier rollers (2)
- ● Sealed and lubricated track chain

240D 270D Undercarriage (continued)

- ▲ ▲ Triple semi-grouser shoes, 28 in. (700 mm)
- ▲ ▲ Triple semi-grouser shoes, 32 in. (800 mm)

Upperstructure

- ● Right- and left-hand mirrors
- ● Vandal locks with ignition key: Cab door / Fuel cap / Service doors / Toolbox
- ● Debris-screening side panel
- ● Remote-mounted engine oil and fuel filters

Front Attachments

- ● Centralized lubrication system
- ● Dirt seals on all bucket pins
- ● Less boom and arm
- ● Oil-impregnated bushings
- ● Reinforced resin thrust plates
- ● Tungsten carbide thermal coating on arm-to-bucket joint
- ▲ ▲ Arm, 9 ft. 9 in. (2.96 m)
- ▲ ▲ Arm, 10 ft. 2 in. (3.11 m)
- ▲ ▲ Arm, 11 ft. 10 in. (3.61 m)
- ▲ ▲ Arm, 12 ft. 4 in. (3.75 m)
- ▲ ▲ Attachment quick-couplers
- ▲ ▲ Boom cylinder with plumbing to mainframe for less boom and arm
- ▲ ▲ Bucket-to-arm clearance adjustable bushing (except ditching buckets)
- ▲ ▲ Buckets: Ditching / Heavy duty / Heavy-duty high capacity / Severe-duty plate lip / Side cutters and teeth
- ▲ ▲ Material clamps
- ▲ ▲ Super-long fronts

Operator's Station

- ● Adjustable independent control positions (levers-to-seat, seat-to-pedals)
- ● AM/FM radio
- ● Auto climate control/air conditioner, 20,000 Btu/hr. (5.9 kW) with heater and pressurizer
- ● Built-in Operator's Manual storage compartment and manual
- ● Cell-phone power outlet, 12 volt, 60 watt, 5 amp
- ● Coat hook
- ● Deluxe suspension cloth seat with 4-in. (100 mm) adjustable armrests
- ● Floor mat
- ● Front windshield wiper with intermittent speeds
- ● Gauges (illuminated): Engine coolant / Fuel
- ● Horn, electric
- ● Hourmeter, electric

*See your John Deere dealer for further information.

240D 270D Operator's Station (continued)

- ● Hydraulic shutoff lever, all controls
 - ● Hydraulic warm-up control
 - ● Interior light
 - ● Large cup holder
 - ● Machine Information Center (MIC)
 - ● Mode selectors (illuminated): Power modes – three / Travel modes – two with automatic shift / Work mode – one
 - ● Multifunction, color LCD monitor with: Diagnostic capability / Multiple-language capabilities / Maintenance tracking / Clock / Theft-deterrent system / System monitoring with alarm features: Auto-idle indicator, engine air cleaner restriction indicator light, engine check, engine coolant temperature indicator light with audible alarm, engine oil pressure indicator light with audible alarm, low-alternator-charge indicator light, low-fuel indicator light, fault code alert indicator, fuel-rate display, wiper-mode indicator, work-lights-on indicator, and work-mode indicator
 - ▲ ▲ Monitor system with alarm features: Hydraulic oil filter restriction indicator light
 - ● Motion alarm with cancel switch (conforms to SAE J994)
 - ● Power-boost switch on right console lever
 - ● Auxiliary hydraulic control switches in right console lever
 - ● Propel pedals and levers
 - ● SAE two-lever control pattern
 - ● Seat belt, 2 in. (51 mm), retractable
 - ▲ ▲ Seat belt, 3 in. (76 mm), non-retractable
 - ● Tinted glass
 - ● Transparent tinted overhead hatch
 - ● Hot/cold beverage compartment
 - ▲ ▲ Air-suspension heated seat
 - ▲ ▲ 24- to 12-volt D.C. radio convertors, 10 amp
 - ▲ ▲ Circulation fan
 - ▲ ▲ Protection screens for cab front, rear, and side
 - ▲ ▲ Window vandal protection covers
- ### Electrical
- ● 80-amp alternator
 - ● Blade-type multi-fused circuits
 - ● Positive terminal battery covers
 - ▲ ▲ Cab extension wiring harness
 - ● JDLink™ Ultimate wireless communication system with 3 years of service
- ### Lights
- ● Work lights: Halogen / One mounted on boom / One mounted on frame

CONTROL OWNING AND OPERATING COSTS

Customer Personal Service (CPS) is part of John Deere's proactive, fix-before-fail strategy on machine maintenance that will help control costs, increase profits, and reduce stress. Included in this comprehensive lineup of ongoing programs and services are:

Fluid analysis program – tells you what's going on inside *all* of your machine's major components so you'll know if there's a problem *before* you see a decline in performance. Fluid analysis is included in most extended coverage and preventive-maintenance agreements.

Component life-cycle data – gives you vital information on the projected life span of components and lets you make informed decisions on machine maintenance by telling you approximately how many hours of use you can expect from an engine, transmission, or hydraulic pump. This information can be used to preempt catastrophic downtime by servicing major components at about 80 percent of their life cycle.

Preventive Maintenance (PM) agreements – give you a fixed cost for maintaining a machine for a given period of time. They also help you avoid downtime by ensuring that critical

maintenance work gets done right and on schedule. On-site preventive maintenance service performed where and when you need it helps protect you from the expense of catastrophic failures and lets you avoid waste-disposal hassles.

Extended coverage – gives you a fixed cost for machine repairs for a given period of time so you can effectively manage costs. Whether you work in a severe-service setting or just want to spread the risk of doing business, this is a great way to custom-fit coverage for your operation. And an extended coverage contract also travels well because it's backed by John Deere and is honored by *all* Deere construction dealers.

Customer Support Advisors (CSAs) – Deere believes the CSA program lends a *personal* quality to Customer Personal Service (CPS). Certified CSAs have the knowledge and skills for helping make important decisions on machine maintenance and repair. Their mission is to help you implement a plan that's right for *your* business and take the burden of machine maintenance off your shoulders.



JOHN DEERE

DKAX240270 Litho in U.S.A. (09-08)

Net engine power is with standard equipment including air cleaner, exhaust system, alternator, and cooling fan at test conditions specified per ISO9249. No derating is required up to 10,000-ft. (3050 m) altitude.

Specifications and design subject to change without notice. Wherever applicable, specifications are in accordance with SAE standards. Except where otherwise noted, these specifications are based on a unit with 42-in. (1065 mm) bucket, 32-in. (800 mm) triple semi-grouser shoes, full fuel tank, and 175-lb. (79 kg) operator; a 240D LC unit with 11,904-lb. (5400 kg) counterweight; and a 270D LC unit with 13,447-lb. (6100 kg) counterweight.

